



County of Sacramento

TRUCK TURNING TEMPLATE REQUIREMENTS

Projects serving or being served by large trucks, or constructing public roadways serving or expected to serve large trucks, must provide vehicle swept path analysis to ensure that site layout and access can accommodate the large trucks. The design vehicle shall be a WB-67 Interstate Semi-Trailer ("WB-67"), unless otherwise approved. Projects proposing to utilize specialized vehicles or tractor trailer combinations shall submit templates for each design vehicle. Driveways not serving trucks (i.e. auto only driveways) do not require swept path analysis, although a signing plan may be required.

The swept path analysis shall be performed using industry standard software and submitted for review in PDF format. Existing or proposed striping shall be shown on the plan. Turning movements must be performed without crossing into oncoming or adjacent lanes, performing any other illegal maneuvers, or taking any non-truck routes. Where public roadways intersect, or a private driveway intersects with a public roadway, trucks must be able to perform concurrent turns without an overlap of the swept path. If trucks cannot legally execute turns with the proposed pavement configuration or site plan, the geometry (e.g. driveway with, curb radius, and/or taper) shall be modified to accommodate the truck's swept path.

Truck turning templates shall be submitted for review and approved prior to the approval of the improvement plans, or prior to approval of entitlements if no improvement plan is being proposed.

The following image depicts the WB-67 template, which shall be used for swept path analysis.

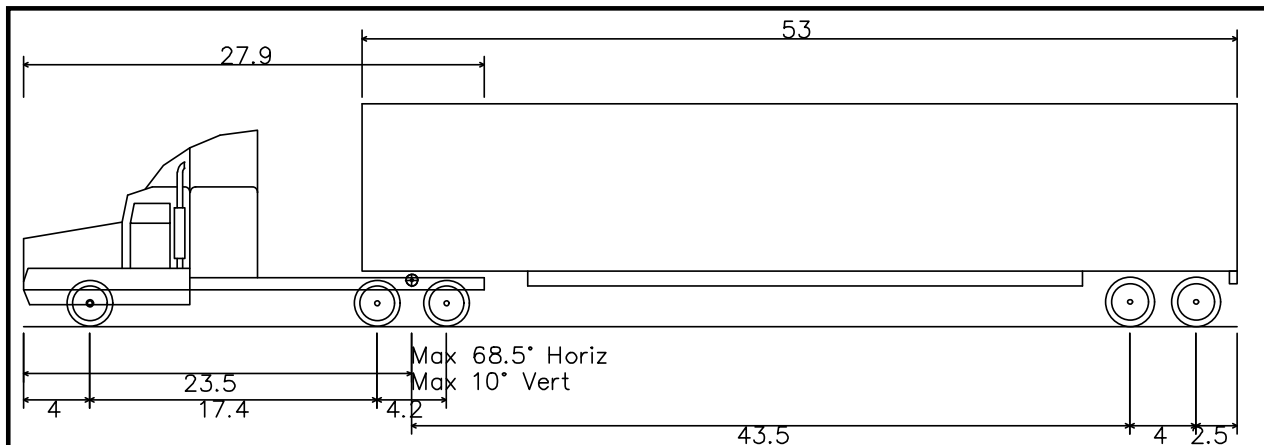

WB-67 – Interstate Semi-Trailer	
Overall Length	73.501ft
Overall Width	8.500ft
Overall Body Height	13.500ft
Min Body Ground Clearance	1.334ft
Max Track Width	8.500ft
Lock-to-lock time	6.00s
Max Steering Angle (Virtual)	28.40°

The following types of projects may require a truck turning template, including but not limited to:

- Truck Repair Services
- Truck Service Station
- Truck Lease or Rental Service
- Truck Sales
- Truck Wash Facilities
- Package Delivery Service
- Truck Parking Lot or Garage
- Vehicle Auction
- Warehousing
- Freight Depot
- Truck, Freight, or Draying Terminal
- Hazardous Waste Storage/Disposal Facility
- Recycling Facilities
- Green Waste Facilities
- Solid Waste Facilities
- Parking and Storage of Commercial/Truck Vehicles
- Loading Dock
- Temporary Storage Containers
- Industrial Use

Truck turning templates shall include at minimum the following:

- Site plan/improvement plans, including access/driveways and frontage/pavement
- Property line
- Right-of-way
- Roadway width
- Existing or proposed striping, including dimensions
- WB-67 (or other approved design vehicle) template and turning radius
- Curb radius dimensions
- Scale
- North arrow
- Name of roads
- All requested movements for WB-67 (or other approved design vehicle)

Truck turning template shall be submitted to Gary Gasperi for review at gasperig@saccounty.gov
For a timely response, please include the project number, parcel number, and contact information.

Gary Gasperi, Senior Civil Engineer
Department of Transportation

GG/dl